

AIPHONE



IP Network Audio-Video Intercom





The image is simulated.

Greater flexibility, covering more applications.

The IX System – getting the job done for a wide range of business applications, while achieving connection and integration with third-party IP systems.

Full IP-based Audio-Video Intercom System

Enables to communicate between an infinite number of door/master stations with no distance limitations. Helps save money as no server is required to build a system.

Integration with other IP-based security systems

Using an existing IP infrastructure, IX System can be integrated with Video Management System, Access Control System, and Network Camera System, etc. Combining security components saves time and resources during set-up and training.

24/7 Monitoring/Recording

Video from door station can be monitored and recorded via third-party VMS/NVR systems. Enhances security level for various applications.

Aiphone offers the ideal intercom system for a diverse range of applications that leverage your IP network.



Offices



Airports



Railways



Parking facilities



Hospitals



Factories



Prisons



Shopping Malls



Schools

Broad coverage through network connections.

Full IP-network compatibility, simple installation, and greater flexibility.

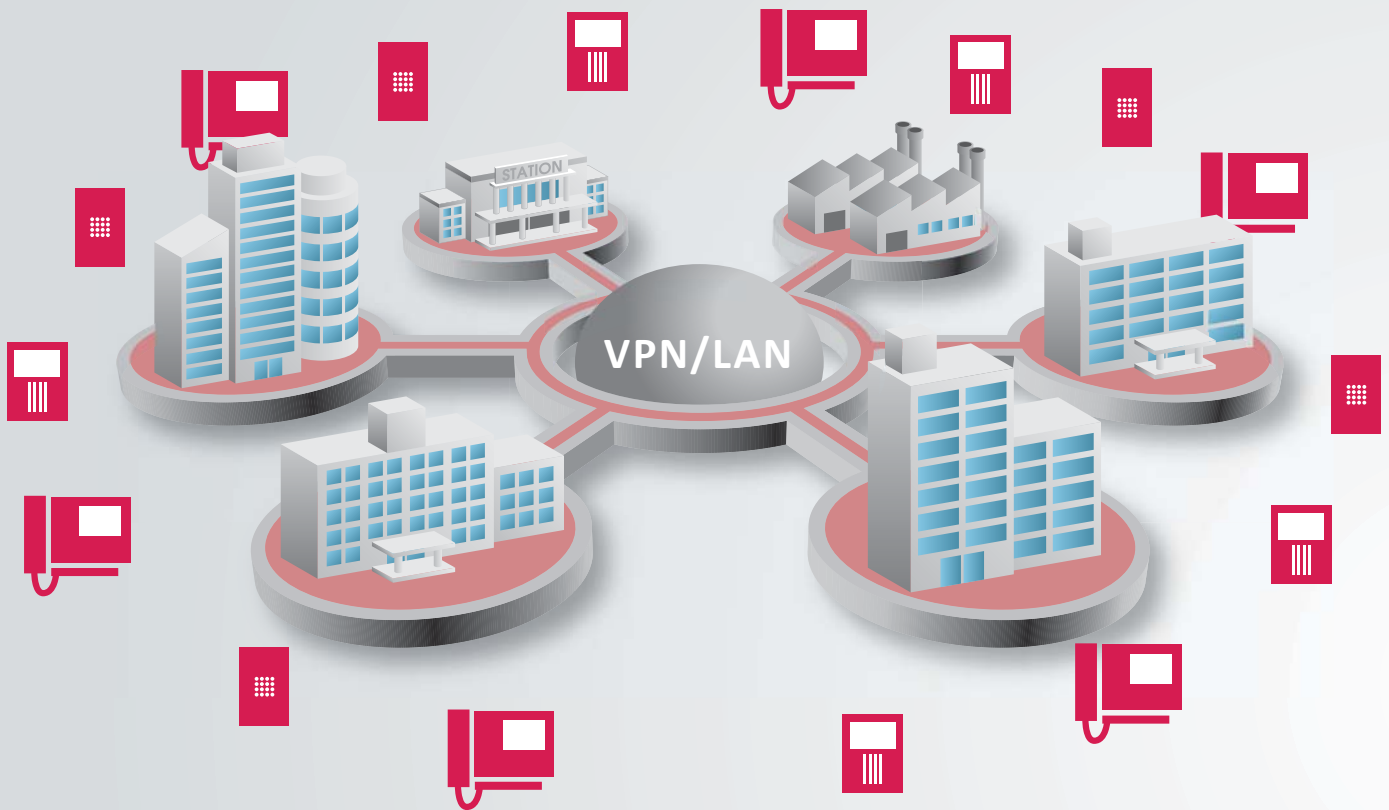

Unlimited number of devices

IP addresses for up to 500 devices can be registered for each master station – plenty of coverage even in large-scale applications.



No wiring-distance limitations

LAN and VPN connections enable implementation over extensive areas and between remote locations. This system allows for closed circuit communication and central control in large facilities, between corporate and satellite offices, and any type of application with multiple locations.

No server configuration results in space savings, reduced installation time, and lower cost

Simply connect the units to Power over Ethernet (PoE) switches. This means no need for a dedicated server, with the additional benefit of eliminating the risk of system downtime due to server malfunction.



PoE design

Electrical power is supplied over the LAN port connection.



New generation of intercom with flexible integratability.

Security enhanced Integration



Compatible with third-party systems

This system is compatible with the ONVIF Profile S-established interface specifications for network camera equipment. This allows the intercom to be used with third-party systems, enabling interoperability of integrated IP systems. The open API allows for configuring IP systems with greater flexibility.



Examples of Integration

Use with a Video Management System and Access Control

Interconnection with an ONVIF Profile S-compatible network camera system lets you transform door station into surveillance cameras for facial identification of visitors. Integrate with video management systems for 24/7 recording. Integration with third-party access control is also possible.

- *VMS (video management system): XProtect® by Milestone Systems
- *Access control: OnGuard® by Lenel

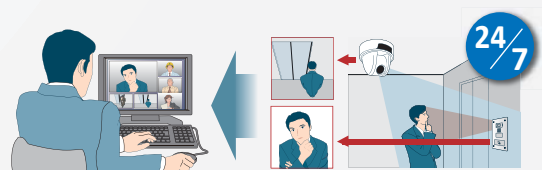

Clearly identify visitors with both the intercom and Network camera.

Custom settings for a variety of



Call Queuing

Master stations can receive up to 20 incoming calls simultaneously. Caller information can be displayed on a call queue list, making it possible to respond selectively to high-priority calls.

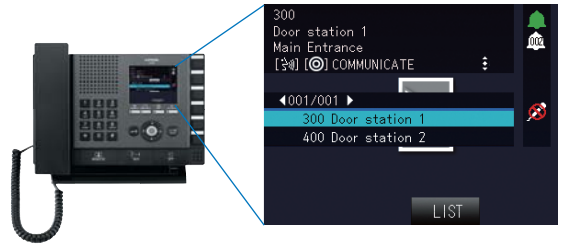

Unicast / Multicast

According to an infrastructure, there is a choice of sending data via Unicast or Multicast. Paging to all stations can be done using Multicast, and for Unicast communication, paging up to 50 stations is possible.

Customize with prerecorded messages

Create and import custom audio files for use as unique voice messages. For visitors at door stations, voice messages let them know that door is open.

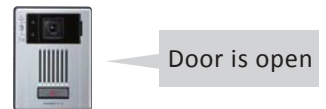

For security guards/receptions at master stations, voice messages help them to identify incoming calls instantly.



Page to all stations or individual groups

Page to all stations and page to preset specific groups is possible. A third-party paging amplifier can be connected for additional coverage.

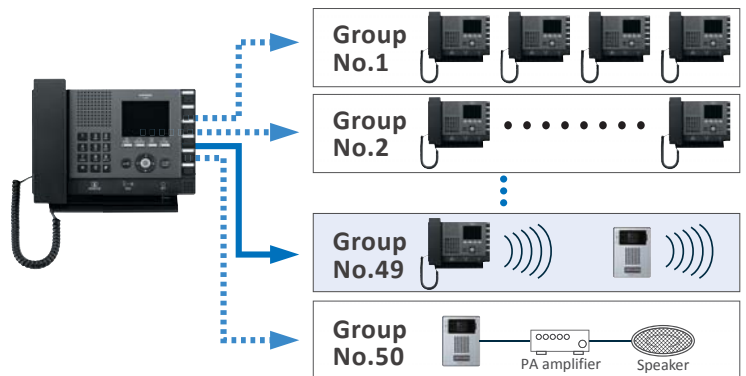

Send E-mail

When master stations are called, IX System can send an E-mail attached with the visitor's picture up to 3 E-mail addresses. Error in the system and health check report can be also sent via E-mail.

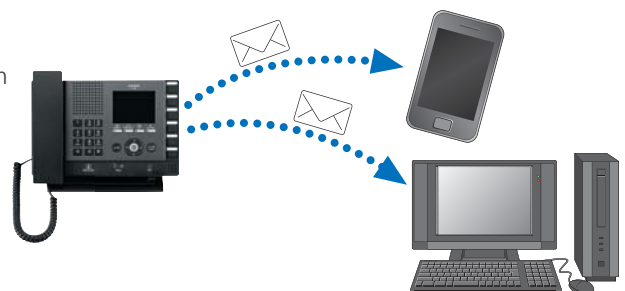

features.

A wide array of call transfer features

The system offers an array of call transfer features that can be set to meet the application.

Manual transfer

A call from a door station can be placed on hold and transferred to another master station manually by the user.



Delay transfer

If no response occurs within a set interval, call is automatically transferred to a pre-programmed master station.



Absent transfer

Call is automatically transferred to a different master station immediately.

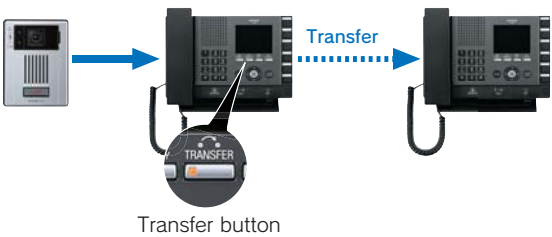

Schedule transfer

Call is automatically transferred to a preset master station during scheduled times, such as after normal business hours.

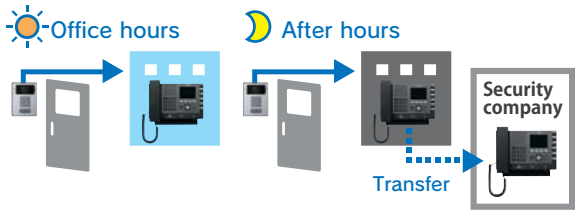

Usage-specific individual calls and simultaneous calls to multiple devices



Door station can call up to 20 master stations simultaneously. Master station can call up to 50 other master stations in a group simultaneously.

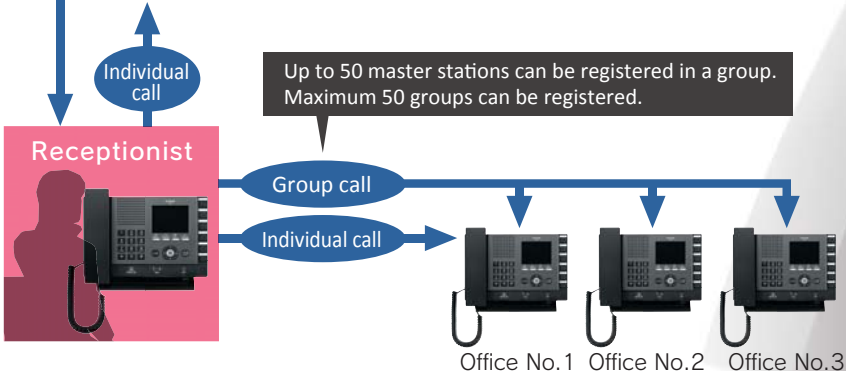

Airports

All-in-one system for Internal communication, Access Control for restricted area, and Video surveillance.

Employees can communicate with each other efficiently and effectively.
Access at public entrances can be controlled with facial identification.
Integration with access control is also possible.

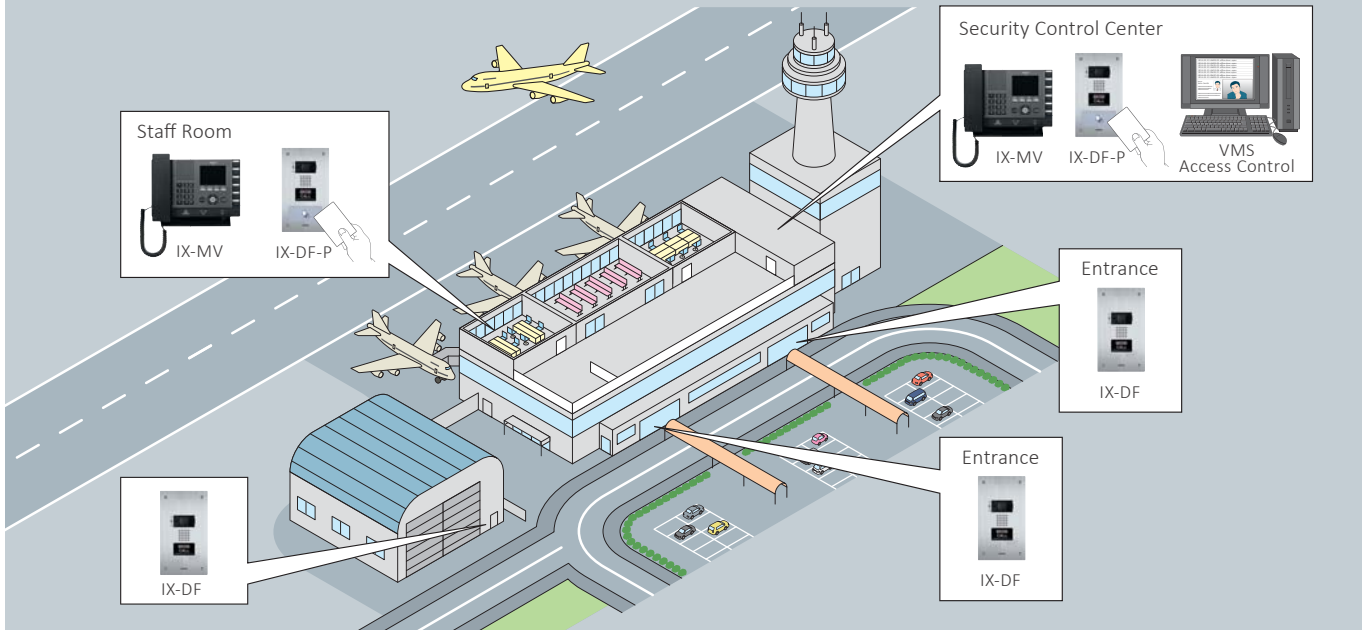

Railways

All-in-one system for Help points, Communication between distant stations, and Video surveillance.

Response can be made to calls and queries from ticket machines, ticket gates, and platforms with video monitoring.
Communication between distant stations is also possible.

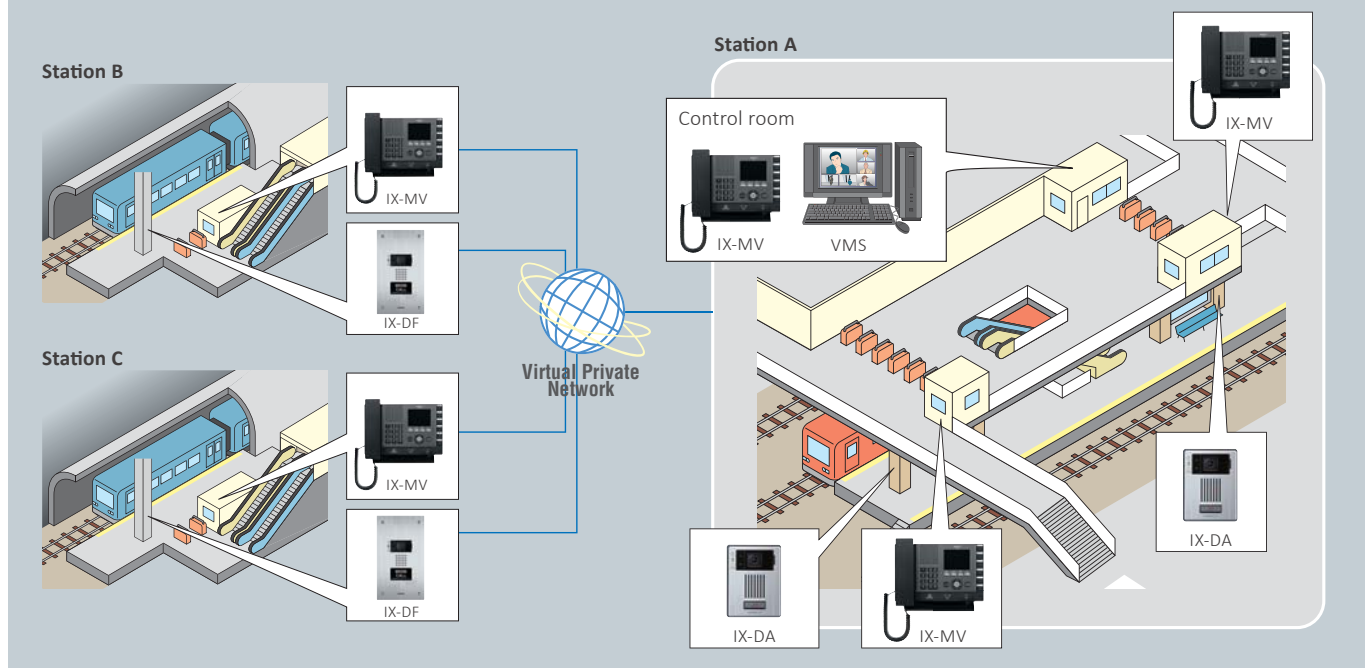

Schools

All-in-one system for Door Entry management, Call transfer for after hours, and Emergency paging.

Management of entry and exit points integrated with access control can be accomplished. The system can also be used to enable teachers and staff members to easily communicate with one another. After hours control for schools within the district can be performed at a central control site.

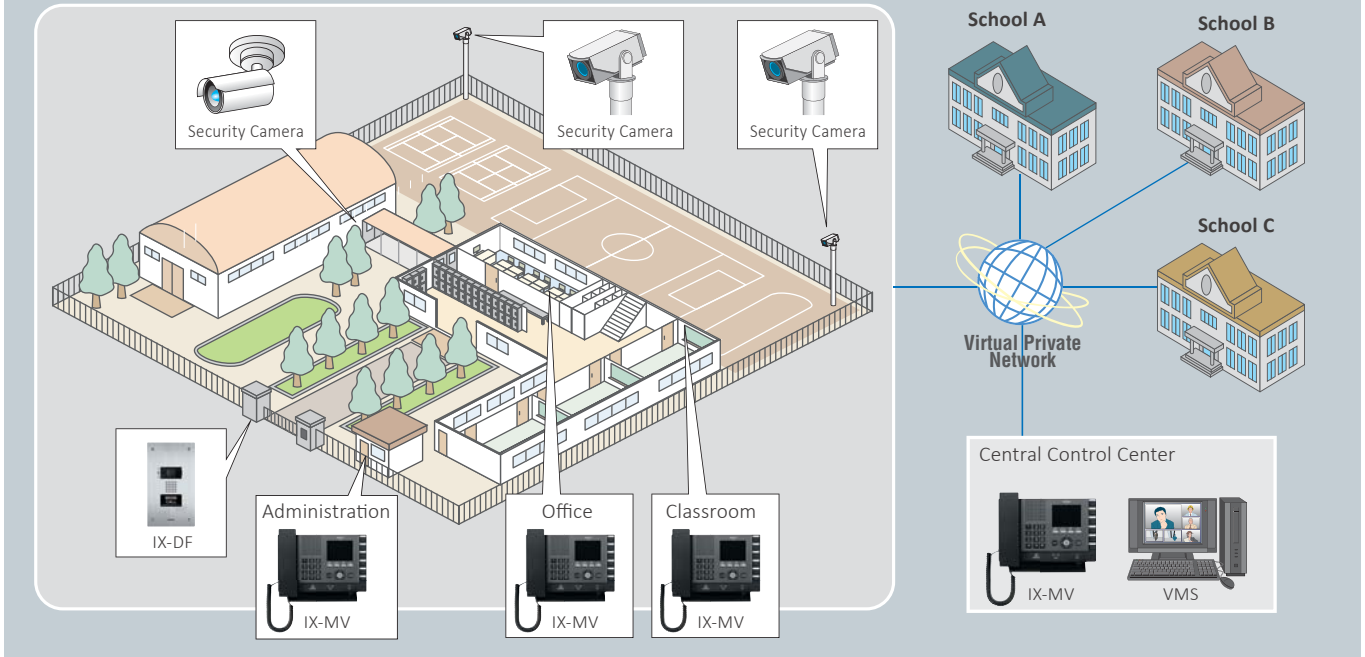

Parking facilities

All-in-one system for Emergency call, Remote control of distant parkings, and Video surveillance.

Audio communication and video identification allows for immediate where assistance is needed. Crime prevention can be enhanced further through simultaneous installation of network cameras.

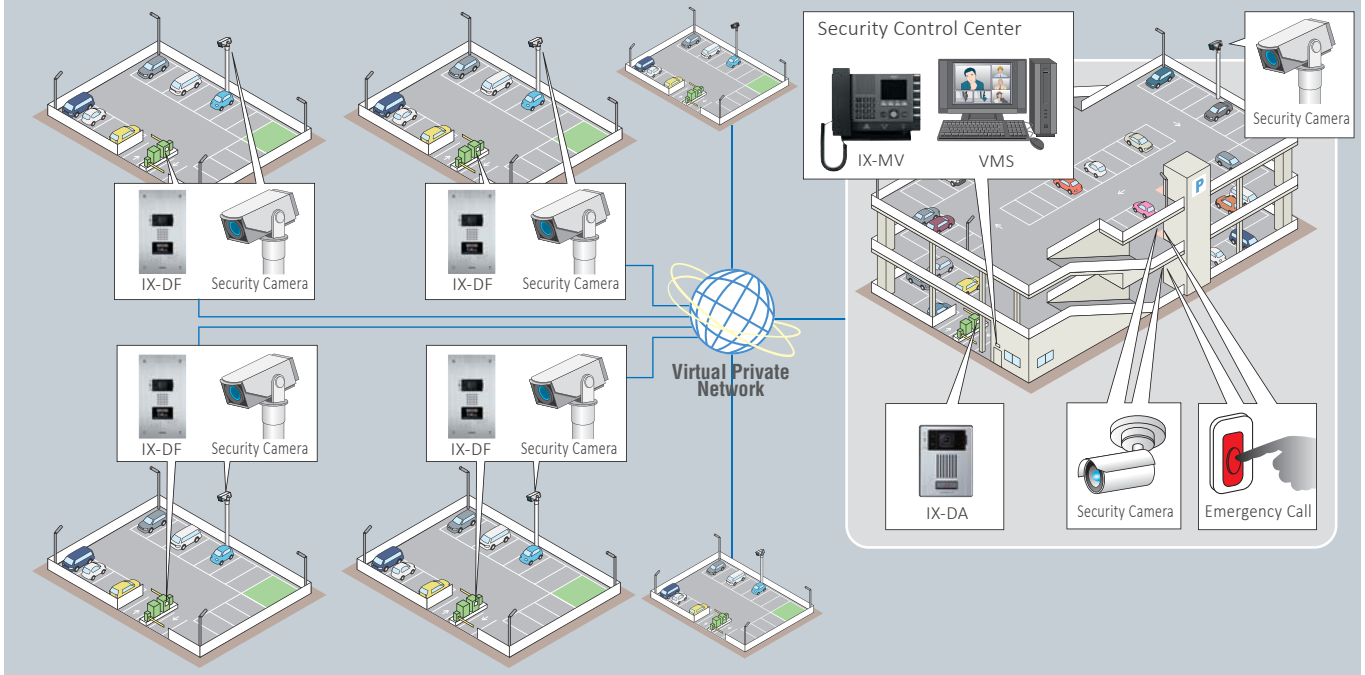

Flexible system configuration to meet your specific application

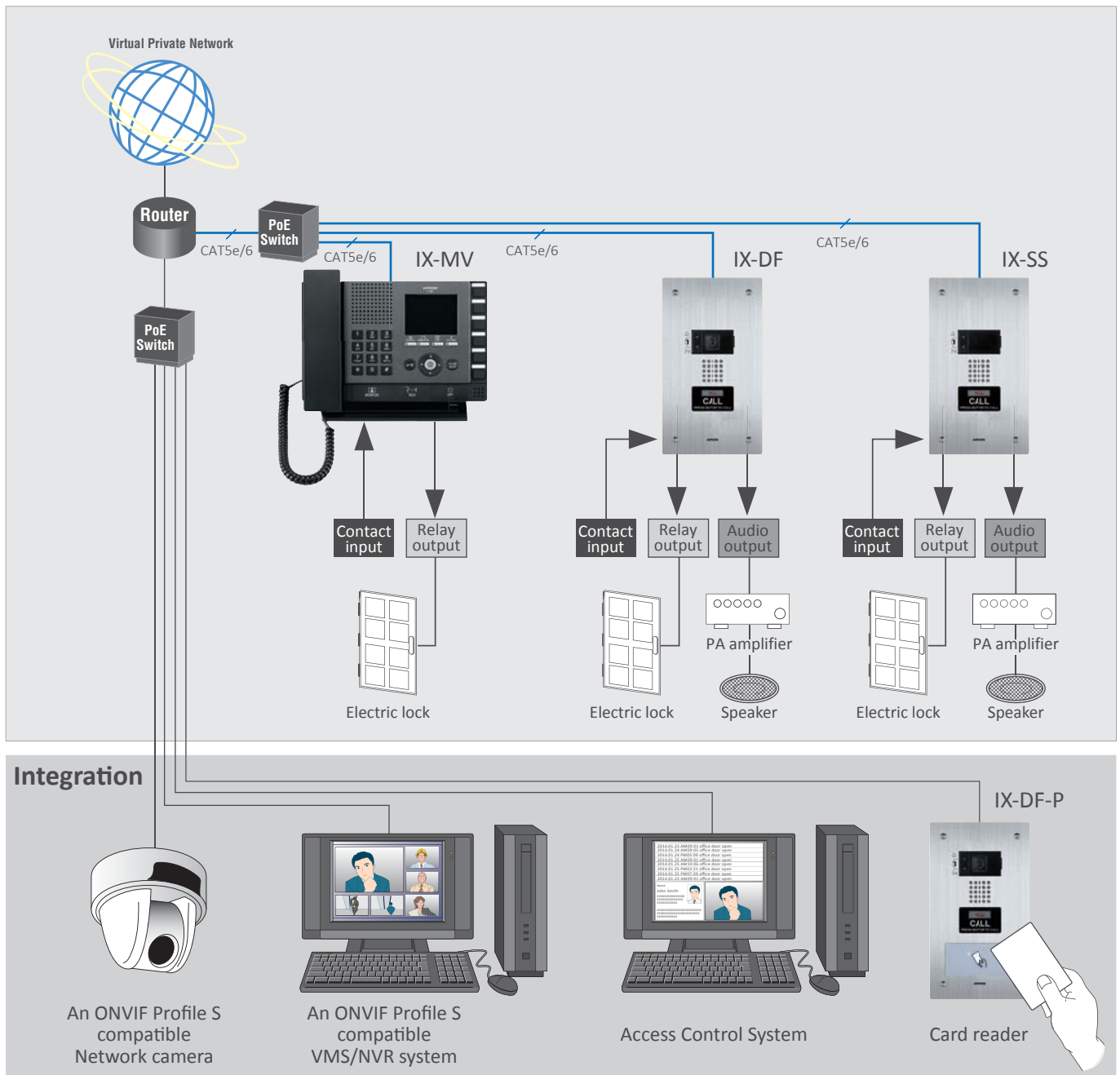

A Guide to Terms

ONVIF (Open Network Video Interface Forum)

The interface specifications established by ONVIF provide standards that enable exchange of live video and audio as well as control information and the like by surveillance cameras and other network video devices feed, even among products from different manufacturers.

VMS (Video Management Software [or "System"])

This refers to video management software using an IP network. Servers and cameras of any make can be installed, enabling configuration of systems matched to user needs.

NVR (Network Video Recorder)

This is a device that records video feed from a network camera over an IP network.

Open API

This refers to a publicly disclosed set of commands and functions that can be used in programming. It enables control of intercom functioning by user programs, and also makes it possible for user programs to acquire information from intercoms.

SYSTEM COMPONENTS

Master Station



● IX-MV

IP Direct Audio + Video Master Station

- 3.5 inch LCD display
- Handset or hands-free
- Door release
- PoE - 802.3af
- Desk stand included (also wall mountable)
- Input/Output : Contact input X 1
Relay output X 1

Video Door Station



● IX-DF

IP Direct Audio + Video Door Station

- Stainless steel
- PoE - 802.3af
- Flush mount
- Mounting box included
- Input/Output : Contact input X 1
Relay output X 1
Audio output X 1

Audio Only Door Station



● IX-SS

IP Direct Audio Door Station

- Stainless steel
- PoE - 802.3af
- Flush mount
- Mounting box included
- Input/Output : Contact input X 1
Relay output X 1
Audio output X 1

Video Door Station



● IX-DF-P

IP Direct Audio + Video Door Station for ProxPoint® Reader

- Same features as IX-DF
- Compatible with HID® ProxPoint® Plus Proximity Card Reader
- Input/Output : Contact input X 1
Relay output X 1
Audio output X 1

* Card reader not included

Video Door Station



● IX-DF-PI

IP Direct Audio + Video Door Station for iCLASS® Reader

- Same features as IX-DF
- Compatible with HID® iCLASS® Smart Card Reader
- Input/Output : Contact input X 1
Relay output X 1
Audio output X 1

* Card reader not included

Video Door Station



● IX-DA

IP Direct Audio + Video Door Station

- Fire-retardant resin
- PoE - 802.3af
- Surface mount
- Input/Output : Contact input X 1
Relay output X 1
Audio output X 1

Audio Only Door Station



● IX-BA

IP Direct Audio Door Station

- Fire-retardant resin
- PoE - 802.3af
- Surface mount
- Input/Output : Contact input X 1
Relay output X 1
Audio output X 1

Specifications

- LAN : Ethernet (10BASE-T, 100BASE-TX)
- Audio Codec : G.711
- Video Codec : H.264/AVC, Motion-JPEG (Master Station, Video Door Station only)
- Network protocol : IPv4, IPv6, TCP, UDP, SIP, HTTP, HTTPS, RTSP, RTP, RTCP, IGMP, MLD, SMTP, FTP, DHCP, NTP, DNS
- Authentication : SSL3.0, TLS1.0, TLS1.1, TLS1.2
- Packet communication method : Unicast, Multicast (Multicast : Master Station, Video Door Station only)
- Other : ONVIF profile S (Master Station, Video Door Station only)

UNIT DIMENSIONS(mm)

IX-MV

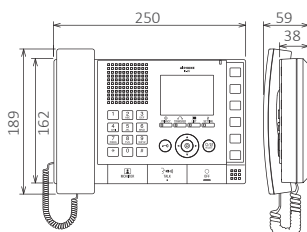

IX-DF

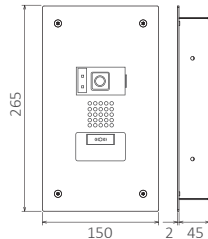

IX-SS

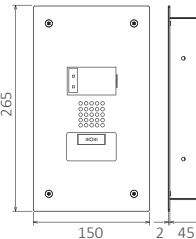

IX-DF-P, IX-DF-PI

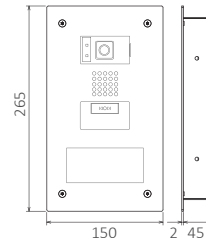

IX-DA

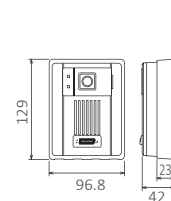

IX-BA

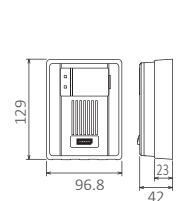

IX
SYSTEM
IP Network Audio-Video Intercom



Distributed by :

Deming Prize



Deming Medal

ISO 9001



ISO 9001 Certified
JQA-0291
AIPHONE CO., LTD.

ISO 14001



ISO 14001 Certified
JQA-EM0453
Headquarters section
Toyota Factory
Taiho Site
AIPHONE CO., LTD.

AIPHONE[®]
Providing Peace of Mind

<http://www.aiphone.net/>

IX(E)1408A

All rights reserved. All statements valid at time of printing. The design and specifications are subject to change without notice for improvement.

Printed in Japan (E)
QB57022AWZ