



Key Switch Exit Button

Model: S40K/S70K

NO/NC/COM;
Stainless steel material.

► Features:

- NO/NC/COM
- Standard key: 2 PCS
- Stainless steel material



Model	S40K		S70K		Side
Size	115*40mm		115*70mm		
View	Front	Back	Front	Back	
Photos					

► Product Parameter

Model	S40K	S70K
Size(mm)	115L*40W*30H	115L*70W*30H
Weight(KG)	0.121	0.135
Power Supply	DC12V	
Output Contact	NO/NC/COM	
Material	Stainless steel panel	



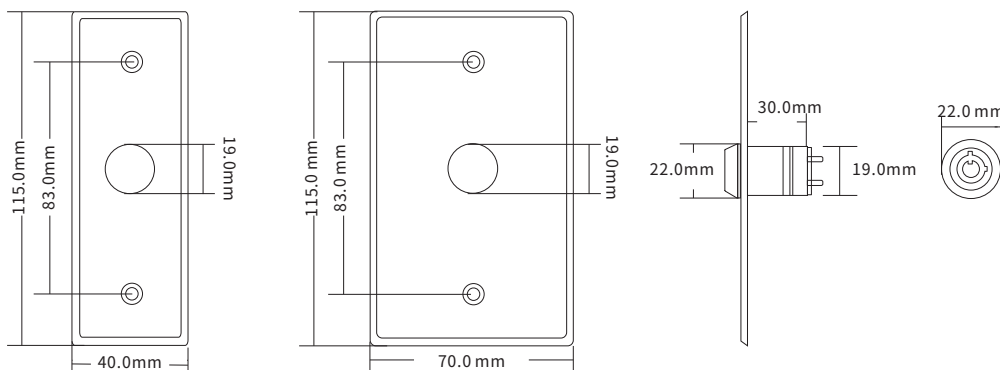

Panel logo	Customizable
Mechanical Life	500,000 Tested aging test qualified
Accessories	Optional Back Box
Operating Temp	-20°C~+55°C(-4-131F)
Operating humidity	0-95% (RH)
Package Quantity	1 PCS/box, 100 PCS/ctn.



► Dimensions



Key Switch Exit Button

► Customized plate is available.

Model	S70K			
Pattern	Normal	Custom - LOGO	Custom - LOGO	Custom - LOGO
Photos				

S40K Optional Back Box			
Model	M40	M40-1	PG40
Material	Zinc alloy (Mirror)	Zinc alloy (Matt)	ABS
Size(mm)	115L*40W*28H	115L*40W*28H	115L*40W*30.5H
Photos			

S70K Optional Back Box			
Model	M70	M70-1	PG70
Material	Zinc alloy (Mirror)	Zinc alloy (Matt)	ABS
Size(mm)	115L*70W*28H	115L*70W*28H	115L*70W*30.5H
Photos	