



Electromechanical Door Solutions

ASSA ABLOY
Opening Solutions



The global leader
in access solutions



Contents

Electric Strikes	5
Electric Mortice Locks	33
Electromagnetic Locking Solutions	55
Electromechanical Bolts	69
Electric Door Operators and Panic Exit Device	85
Electric Window Actuators	95



ASSA ABLOY

ASSA ABLOY in brief

ASSA ABLOY is the global leader in door opening solutions, dedicated to satisfying end-user needs for security, safety and convenience.

ASSA ABLOY is represented in all major regions, on both mature and emerging markets, with leading positions in Australia and much of Europe and North America. In the rapidly growing electromechanical security sector, the Group has a leading position in fields such as electromechanical products, access control, identification technology, automatic doors, commercial, government and institutional security.

Since its founding in 1994, ASSA ABLOY has grown from a regional company to an international group. As the world's leading lock group, ASSA ABLOY offers a more complete range of door opening solutions than any other company on the market.

ASSA ABLOY Australia

Local manufacturing

ASSA ABLOY Australia has long been developing innovative electromechanical products. We focus on extensive market research, developing products that exceed market demands.

ASSA ABLOY Australia boasts a precision manufacturing facility and innovative design centre in Melbourne.

Extensive product range

ASSA ABLOY Australia offers one of the most comprehensive electromechanical product ranges in the Australian market today. We specialise in supplying door solutions for all market segments and industries. Our range includes electromechanical solutions for almost any application.

Premium quality and reliability

Our product range is designed and manufactured to surpass the highest Australian and international standards. The Melbourne manufacturing facility includes a state-of-the-art NATA accredited test laboratory. This ensures the undisputed quality and reliability known on the market today.



Electric Strikes



EL110 Electric Cabinet Lock	6
ES100 Series Electric Strike	8
ES110 Series Electric Strike	10
ES150 Surface Mounted Electric Strike	14
ES200 Series Non Monitored Electric Strike	16
ES2000 Series Monitored Electric Strike	18
ES2100 Series Monitored Electric Strike	20
ES2600 Series Monitored Electric Strike	22
ES300 Series Electric Strike	24
ES3000 Monitored Series Electric Strike	26
ES9000 Series Pre-Load Strike	28
ES9100 Series Pre-Load Strike	30

EL110 Electric Cabinet Lock

General Description

The EL110 electric cabinet lock is a compact, cast aluminium lock specially designed for cabinets having either swing or sliding doors. The cabinet lock can be surface mounted either vertically or horizontally and offers maximum flexibility for ease of installation.

EL110 can also be controlled by any existing access control system or simply controlled through a remote keypad or keyswitch. The EL110 is cost efficient, robust, easy to install and suitable for one or multiple cabinet applications.

Key Features

- Fail safe/fail secure changeable on site
- Flexible alignment:
has a 5mm XY adjustment after installation
- Low current consumption:
uses only 187mA @ 12Vdc
- Available in 12 or 24Vdc
- Self latching in fail secure mode
- Solenoid rated for continuous use
- Australian designed
- **TRICARE**® 5 Year Warranty

Applications

- Cabinet locking
- Swing or sliding cabinet doors



Standards and Compliance

 CE Approved

 C-Tick Certified

EL110 Electric Cabinet Lock

Front Engagement

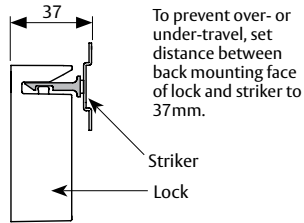

Lock and Strike Dimensions

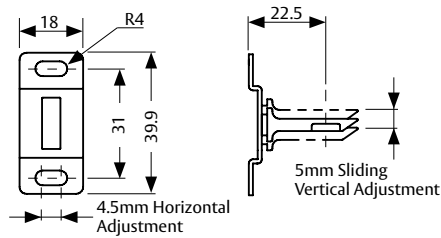

Side Engagement

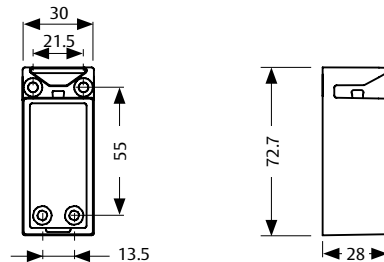
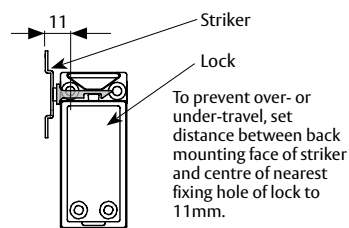

EL110 Technical Information

Voltage	12 or 24Vdc
Current	187mA @ 12Vdc, 87mA @ 24Vdc
Solenoid	Solenoids are rated for continuous use
Monitoring	None
Strength	Holding force 150kg
Endurance	Cycle tested to 1,000,000 operations
Environment	Operational temperature range -20c to +60c
Body	Cast Aluminium Construction

Specification Statement

The strike which is to be surface mounted and constructed of cast aluminium, should be self latching when used in fail secure mode. The lock must be capable of being changed from fail safe to fail secure on site. Lock alignment must be adjustable up to 5mm in both "x" and "y" directions both during and after installation. The lock should consume not greater than 187mA @12Vdc or 87mA @ 24Vdc and have a solenoid rated for continuous use. Electrical certifications must include CE and C-tick.

Ordering Information

Product Description	Part Number
12V Fail Safe Cabinet Lock	111301-000
12V Fail Secure Cabinet Lock	111302-000
24V Fail Secure Cabinet Lock	111304-000

ES100 Series Electric Strike

General Description

The ES100 is a cost efficient robust electric strike with a solid construction of one-piece cast aluminium body and stainless steel striker. The ES100 offers the same level of security and reliability usually provided by more expensive electric locking solutions.

Extension lips are available to accommodate the installation of electric strikes on door frames with different thickness. The ES100 product range of patented electric strikes are suitable for use with all access control installations where flexibility, security and lower cost are required.

Key Features

- Fail safe/fail secure changeable on site
- Stainless steel striker for extra strength and durability
- Stainless steel locking pins
- Multi Voltage 12Vdc and 24Vdc
- Optional mounting kit
- Installation template
- Suitable For 15mm latch with a 3mm door gap
- Australian designed
- **TRICARE**® 5 Year Warranty

Applications

- Exposed areas
- High traffic areas
- Open in/open out doors
- Suitable for use with all access control systems



Standards and Compliance



Successfully fire rated up to 4hrs on fire door assemblies in accordance with AS1905.1. 2005 (Part 1: Fire resistant door sets)



Approved to UL1034 (highest level)



CE Approved



C-Tick Certified

Weather Resistant IP56

ES100 Series Electric Strike

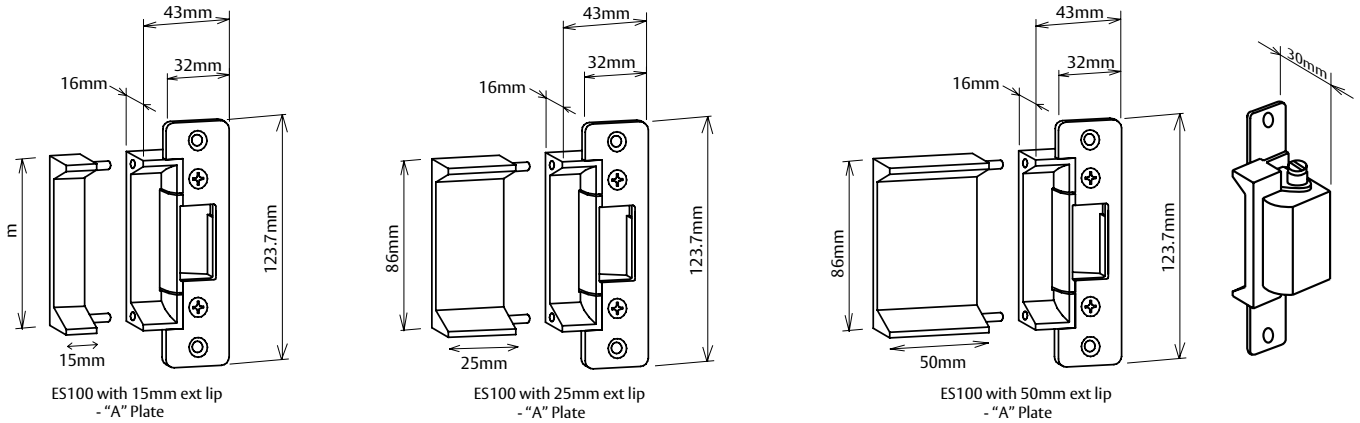

ES100 Technical Information

Voltage	12Vdc and 24Vdc
Current	250 mA @ 12Vdc - 125mA @ 24Vdc
Solenoid	Solenoids are rated for continuous use.
Monitoring	None
Holding Force	680 kg Static Strength Rating
Endurance	Cycle tested to 1,000,000 operations
Environment	Operational temperature range -20°C to +60°C Weather resistant construction. (IP56)
Body	Cast Aluminium Construction
Keeper	Stainless Steel

Ordering Information

Product Description	Part Number
ES101 12/24Vdc PTL W/Res A-Type Rnd Cnr S/Steel F/Plate with Extension Lip Holes	110101-030M
ES101 12/24Vdc PTL W/Res A-Type Rnd Cnr S/Steel F/Plate Lipless	110101-070M

Note: For additional face plate options see page 12.

Abbreviation Key	
PTO	Power to Open (Fail Secure)
PTL	Power to Lock (Fail Safe)
W/RES	Weather Resistant
A-Type	Short style face plate with round corners
H-Type	Long style face plate with square corners
H/RND	Long style face plate with round corners (Accessory)
LIPLESS	No Lip on the Lock body
S/STEEL	Stainless Steel
F/PLATE	Face Plate

Accessories

Product Description	Part Number
15mm Extension Lip	220100-506
25mm Extension Lip	220100-507
50mm Extension Lip	220100-508
Mounting Kit	220200-518
13mm Rebate Plate	210100-523

Specification Statement

Where Power to Lock and Power to Open functions may be required in the same building, the strike must be interchangeable from either "Power to Lock" or "Power to Open" on site.

The electric strike should not consume current greater than 250 mA @ 12Vdc - 125mA @ 24Vdc and have a solenoid suitable for continuous use. Certifications must include CE, C-tick and 4hr fire rating.

The strike should have a minimum holding force of 680kg, and an endurance rating of 1 million cycles.

ES110 Series Electric Strike

General Description

The ES110 is a cost efficient robust electric strike with a solid construction of one-piece cast aluminium body and stainless steel striker. Having a deeper than normal strike-keeper area, ES110 is designed to work with an extensive range of locks and offers the same level of security and reliability usually provided by more expensive electric locking solutions.

Extension lips are available to accommodate the installation of electric strikes on door frames with different thickness. The ES110 product range of patented electric strikes are suitable for use with all access control installations where flexibility, security and lower cost are required.

Key Features

- Fail safe/fail secure changeable on site
- Stainless steel striker for extra strength and durability
- Stainless steel locking pins
- Multi Voltage 12Vdc and 24Vdc
- Optional mounting kit
- Installation template
- Suitable For 18mm latch with a 3mm door gap
- Australian designed
- **TRICARE**® 5 Year Warranty

Applications

- Exposed areas
- High traffic areas
- Open in/open out doors
- Suitable for use with all access control systems



Standards and Compliance



Successfully fire rated up to 4hrs on fire door assemblies in accordance with AS1905.1. 2005 (Part 1: Fire resistant door sets)



Approved to UL1034 (highest level)



CE Approved



C-Tick Certified

Weather Resistant IP56

ES110 Series Electric Strike

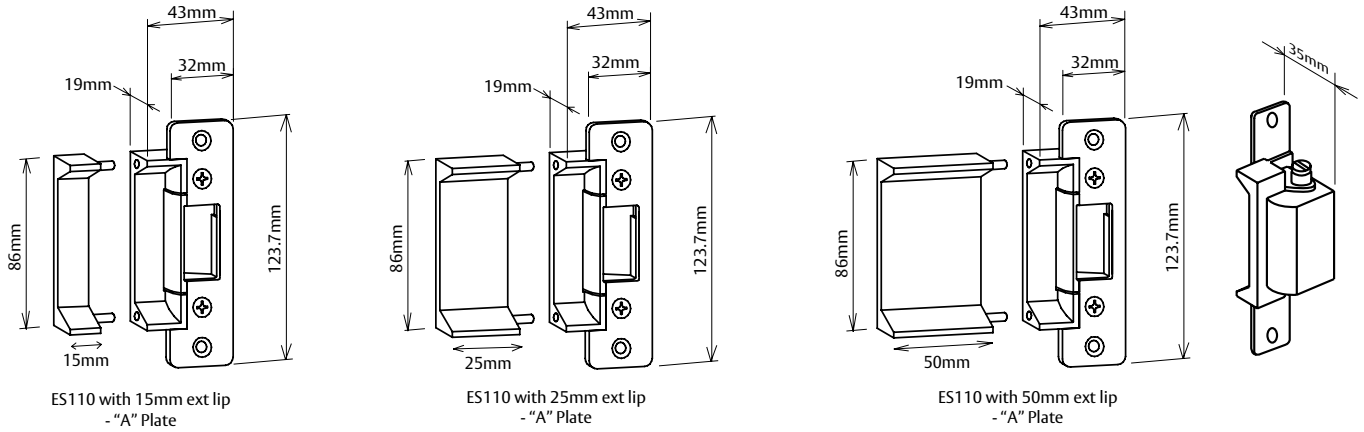

ES110 Technical Information

Voltage	12Vdc and 24Vdc
Current	250 mA @ 12Vdc - 125mA @ 24Vdc
Solenoid	Solenoids are rated for continuous use
Monitoring	None
Holding Force	680 kg Static Strength Rating
Endurance	Cycle tested to 1,000,000 operations
Environment	Operational temperature range -20°C to +60°C Weather resistant construction (IP56)
Body	Cast Aluminium Construction
Keeper	Stainless Steel

Ordering Information

Product Description
ES111 12/24Vdc PTL W/Res A-Type Rnd Cnr S/Steel F/Plate & H/Rnd
ES111 12/24Vdc PTL W/Res H-Type Sq Cnr S/Steel F/Plate Lipless
ES111 12/24Vdc PTL W/Res-H-Type Sq Cnr S/Steel F/Plate & H/Rnd
ES111 12/24Vdc PTL W/Res A-Type Rnd Cnr S/Steel F/Plate Lipless & H/Rnd
ES112 12/24Vdc PTO W/Res A-Type Rnd Cnr S/Steel F/Plate & H/Rnd
ES112 12/24Vdc PTO W/Res H-Type Sq Cnr S/Steel F/Plate

Part Number	Product Description	Part Number
110111-060M	15mm Extension Lip	220110-502
110111-150M	25mm Extension Lip	220110-503
110111-160M	50mm Extension Lip	220110-504
110111-190M	Mounting Kit	220200-518
110112-060M	Rebate Plate	210100-523
110112-140M		

Note: For additional face plate options see over the page
Note: Strikes comes standard with Extension Lip Holes

Abbreviation Key	
PTO	Power to Open (Fail Secure)
PTL	Power to Lock (Fail Safe)
W/RES	Weather Resistant
A-Type	Short style face plate with round corners
H-Type	Long style face plate with square corners
H/RND	Long style face plate with round corners (Accessory)
LIPLESS	No Lip on the Lock body
S/STEEL	Stainless Steel
F/PLATE	Face Plate

Specification Statement

Where Power to Lock and Power to Open functions may be required in the same building, the strike must be interchangeable from either "Power to Lock" or "Power to Open" on site.

The electric strike should not consume current greater than 250 mA @ 12Vdc - 125mA @ 24Vdc and have a solenoid suitable for continuous use. Certifications must include CE, C-tick and 4hr fire rating.

The strike should have a minimum holding force of 680kg, and an endurance rating of 1 million cycles.

Accessories

ES100 / ES110 Faceplate Options

Faceplates

Faceplate Style	l	w	a	Part Number
A (ANSI Short) - SS	123.7	31.7	104.8	210100-544
B (ANSI Long) - SS	201.6	36.3	185.7	210100-530

Note: SS - Stainless Steel

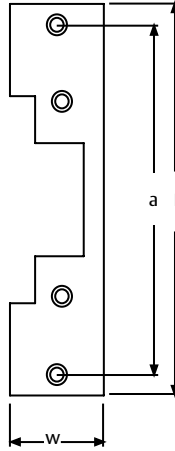

Faceplate Style	l	w	d	a	Part Number
J - AL	201.6	32	16	185.7	210100-523

Note: AL - Aluminium

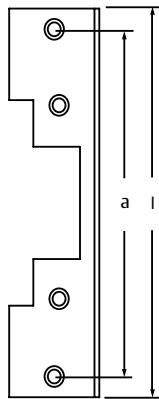
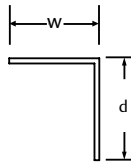

Faceplate Style	l	w	a	b	Part Number
D (Euro Sash RH) [DIN Left] - SS	209	31.7	60	11.7	219100-538
E (Euro Sash LH) [DIN Right] - SS	209	31.7	60	11.7	219100-539
F (UK Sash RH) [DIN Left] - SS	251	25	74	12	210100-528
G (UK Sash LH) [DIN Right] - SS	251	25	74	12	210100-527

Note: SS - Stainless Steel

All face plates are sold separately

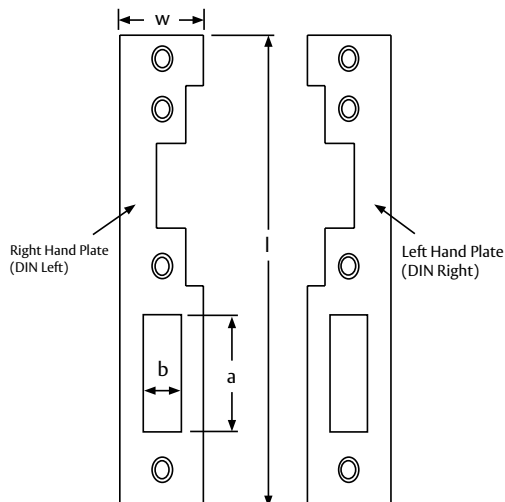



ES150 Series Surface Mounted Electric Strike

General Description

ES150 is a surface mounted electric strike suitable for use with rim or surface type dead latches. This strike is easy to install and can be simply controlled by a keypad, keyswitch or integrated into any access control system.

ES150 offers high levels of security and features usually provided by more expensive electric locking solutions. The electric strike can be easily installed on steel and wooden door frames.

Key Features

- Fail safe/fail secure changeable on site
- Easy installation suitable for steel and wooden door frames
- Stainless steel striker for extra strength and durability
- Multi Voltage 12Vdc and 24Vdc
- Solenoid rated for continuous use
- IP56 weather resistant
- Australian designed
- **TRICARE**® 5 Year Warranty

Applications

- Surface or rim mounted applications
- Suitable for use with all access control systems
- Exposed areas
- Exterior Applications



Standards and Compliance

 CE Approved

 C-Tick Certified

IP56 Rated

ES150 Series Surface Mounted Electric Strike

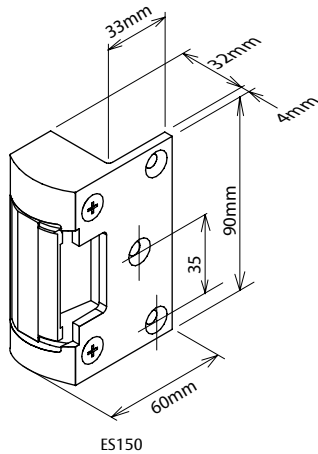

ES150

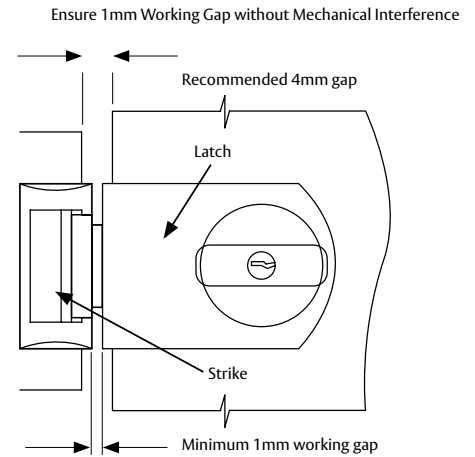
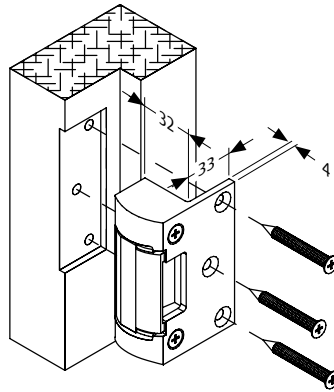

ES150 Technical Information

Voltage	12VDC and 24Vdc
Current	250mA @12Vdc / 125mA @ 24VDC
Solenoid	Solenoids rated for continuous use
Monitoring	None
Holding Force	680kg Static Strength Rating
Endurance	Cycle tested to 1,000,000 operations
Environment	Operational temperature range - 20°C to +60°C Weather resistant (IP56)
Body	Solid Stainless Steel Construction
Keeper	Stainless Steel

Ordering Information

Product Description	Part Number
ES151 12/24Vdc PTL W/Res	110151-010M
ES152 12/24Vdc PTO W/Res	110152-010M

Abbreviation Key	
PTO	Power to Open (Fail Secure)
PTL	Power to Lock (Fail Safe)
W/RES	Weather Resistant
A-Type	Short style face plate with round corners
H-Type	Long style face plate with square corners
H/RND	Long style face plate with round corners (Accessory)
LIPLESS	No Lip on the Lock body
S/STEEL	Stainless Steel
F/PLATE	Face Plate

Specification Statement

The electric strike must be suitable for surface mount applications for use with rim or surface mount door locks.

Where Power To Lock and Power To Open functions may be required in the same building, an individual strike is interchangeable from either "Power to Lock" or "Power to Open" on site.

The electric strike should not consume current greater than 250mA @ 12Vdc / 125mA @ 24Vdc. Certifications must include CE and C-Tick.

The strike should be tested to 1 million operations and have a minimum holding force not less than 680kg.

ES200 Series Electric Strike

General Description

The ES200 series electric strikes are high security products manufactured from cast stainless steel and designed for use with all access control systems. The strikes are suitable for use with hinged doors which require either fire or security control as part of a building management system.

These strikes are flexible and can be changed from fail safe to fail secure, mounted on the left or right hand side of the door and are available in 12 or 24Vdc.

They offer a strong, dependable and long-lasting electric strike solution.

Key Features

- Fail safe/fail secure changeable on site
- High security
- 4 Hour fire rating
- 850kg holding force
- 1 million cycles endurance rating
- Cast stainless steel body
- Stainless steel locking pins
- Low Current consumption – Max 175mA @12Vdc
- Mounting kit supplied as standard
- Australian designed
- **TRICARE**® 5 Year Warranty

Applications

- High traffic areas
- Fire rated door sets
- Open in/open out doors
- Suitable for use with all access control systems





Standards and Compliance

S3 (Security) Australian Lock Standard (AS4145.2.1993)

D3 (Durability) Australian Lock Standard (AS4145.2.1993)

BSI BS 5872 Approved

 Successfully fire rated up to 4hrs on fire door assemblies in accordance with AS1905.1. 2005 (Part 1: Fire resistant door sets)

 Approved to UL1034 (highest level)

 CE Approved

 C-Tick Certified

ES200 Series Electric Strike

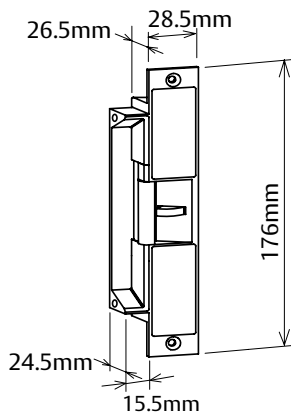

ES200 with 75mm Extension Lip

ES200 Technical Information

Voltage	12 or 24Vdc
Current	175 mA @ 12Vdc - 88 mA @ 24Vdc
Solenoids	Solenoids are rated for continuous use
Monitoring	None
Holding Force	850kg Static Strength Rating
Endurance	Cycle tested to 1,000,000 operations
Latch	Suitable for 15mm latch bolt with 3mm door gap
Environment	Operational temperature range -20°C to +60°C
Body	Solid Stainless Steel Construction
Keeper	Stainless Steel

Ordering Information

Product Description	Part Number
12V Fail Safe Electric Strike	110201-000
12V Fail Secure Electric Strike	110202-000
24V Fail Safe Electric Strike	110203-000

Note: If an Extension Lip is required use Model ES2100 Page 20.

Specification Statement

The strike should be constructed of solid stainless steel, have a minimum holding force of 850kg and have an endurance rating of 1 million cycles. The one strike must be changeable from fail safe to fail secure on site where required. The strike should not consume current greater than 175mA at 12Vdc and have a solenoid rated for continuous use. Certifications must include CE, C-Tick and 4 hr fire rating.

Accessories

Product Description	Part Number
13mm Rebate Plate	210100-541

ES2000 Series Monitored Electric Strike

General Description

The ES2000 series electric strikes are fully monitored high security products manufactured from cast stainless steel and designed for use with all access control systems. The strikes are suitable for use with hinged doors which require either fire or security control as part of a building management system.

These strikes are flexible and can be changed from fail safe to fail secure, mounted on the left or right hand side of the door and are available in 12 Vdc.

They offer a strong, dependable and long-lasting electric strike solution with a 850kg holding force and endurance rating of 1 million cycles.

Key Features

- Fully monitored – strike locked and door latched
- Fail safe/fail secure changeable on site
- High security
- 4 Hour fire rating
- 850kg holding force
- 1 million cycles endurance rating
- Cast stainless steel body
- Stainless steel locking pins
- SCEC Endorsed
- Low Current consumption – Max 175ma @12Vdc
- Solenoid rated for continuous use
- Mounting kit supplied as standard
- Australian designed
- **TRICARE**® 5 Year Warranty

Applications

- High traffic areas
- Fire rated door sets
- Open in/open out doors
- Suitable for use with all access control systems





Standards and Compliance

S3 (Security) Australian Lock Standard (AS4145.2.1993)

D3 (Durability) Australian Lock Standard (AS4145.2.1993)

BSI BS 5872 Approved

 Successfully fire rated up to 4hrs on fire door assemblies in accordance with AS1905.1. 2005 (Part 1: Fire resistant door sets)

 Approved to UL1034 (highest level)

 CE Approved

 C-Tick Certified

SCEC endorsed for secure areas

ES2000 Series Monitored Electric Strike

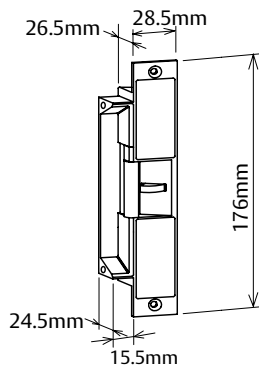

ES2000 with 75mm Extension Lip

ES2000 Technical Information

Voltage	12Vdc
Current	175 mA @ 12Vdc
Solenoids	Solenoids are rated for continuous use
Monitoring	Solenoid Monitor - 1 amp NO/NC microswitch Door/Latch Monitor - 1 amp NO/NC microswitch
Holding Force	850kg Static Strength Rating
Endurance	Cycle tested to 1,000,000 operations
Latch	Suitable for 15mm latch bolt with 3 mm door gap
Environment	Operational temperature range - 20°C to +60°C
Body	Solid Stainless Steel Construction
Keeper	Stainless Steel

Ordering Information

Product Description	Part Number
12V Fail Safe Electric Strike	112001-000
12V Fail Secure Electric Strike	112002-000
12v ES2400 Fail Safe Electric Strike	112401-000

Note: If an Extension Lip is required use Model ES2100 Page 20.

Specification Statement

The strike should be constructed of solid stainless steel, have a minimum holding force of 850kg and have an endurance rating of 1 million cycles. Monitoring must include independent door / latch & solenoid monitoring. The one strike must be changeable from fail safe to fail secure on site where required. The strike should not consume current greater than 175mA at 12Vdc and have a solenoid rated for continuous use. Certifications must include CE, C-Tick and 4 hr fire rating.

Accessories

Product Description	Part Number
13mm Rebate Plate	210100-541

ES2100 Series Monitored Electric Strike



General Description

The ES2100 is the latest product to join the iconic Trimec range of electric strikes. Tested in accordance with Australian standards this strike offers superior strength, and is durability tested to 1.5 million operations.

Standard features include variable voltage, patented field selectable fail safe/fail secure mode change and a unique integrated door position switch.

Integrated Door Position Switch

The ES2100 now offers a unique new monitoring feature not available in other strikes on the market today. The strike has an integrated reed switch that when combined with a specialised Lockwood mortice lock, provides door position monitoring. The strike is supplied with a standard door magnet for use with cylindrical latches. Lockwood mortice locks and face plate accessories are sold separately.

Key Features

- Patented field selectable fail safe/fail secure
- Multi voltage 10–30Vdc
- Fully monitored:
 - Integrated door position (reed) switch
 - Solenoid/Locked
 - Latch position

- 1000kg holding force
- 4hr fire rating
- Mounting tabs as supplied standard
- **TRIGARE**® 5 Year Warranty

Applications

- High traffic areas
- Fire rated door sets
- Open in/open out doors
- Suitable for use with all access control systems
- Doors requiring additional door position monitoring

Standards and Compliance

SL8 (Security) Australian Lock Standard (AS4145.2.2008)

D8 (Durability) Australian Lock Standard (AS4145.2.2008)



Successfully fire rated up to 4hrs on fire door assemblies in accordance with AS1905.1. 2005



CE Approved



C-Tick Certified

SCEC Approved for Security Level 3

IP 54 Rated

ES2100 Series Monitored Electric Strike

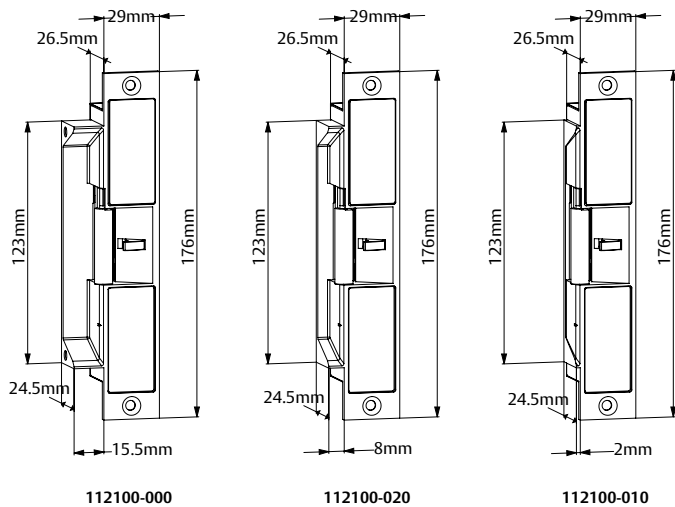

ES2100 Electric Strike

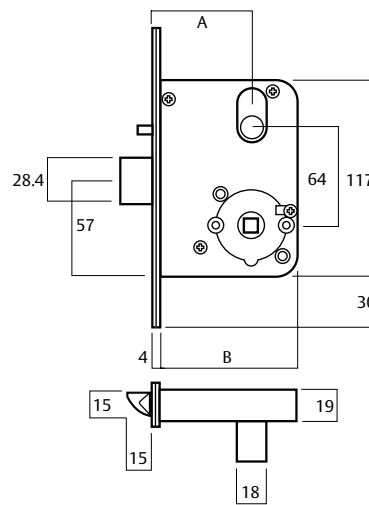

3570 Series Mortice Lock

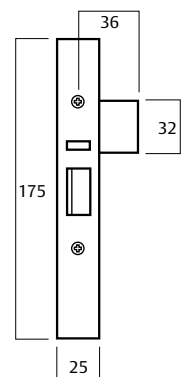

Magnet Faceplate

ES2100 Technical Information	
Voltage	Variable 10–30Vdc
Current	200mA @ 12Vdc – 120mA @ 24Vdc
Solenoids	Rated for continuous use
Monitoring	Latch Strike locked Door position (reed switch)
Holding force	1000kg static strength rating
Endurance	Cycle tested to 1.5 million operations
Latch	Suitable for 15mm latch bolt with 3mm door gap
Body	Stainless Steel
Keeper	Stainless Steel
Environment	Operational temperature range -20°C to +60°C

	STD Backset	Extended Backset
Dimension A	60	127
Dimension B	84	151

Specification Statement

The strike should be constructed of solid stainless steel, have a minimum holding force of 1000kg and an endurance rating of 1.5 million cycles. Monitoring must include independent latch and solenoid monitoring. The strike shall have an integrated reed switch for door position monitoring and used in conjunction with Lockwood 3572MAGSC mortice lock or tubular latch with door magnet. Certifications must include CE, C-tick and 4 hr fire rating.

Ordering Notes:

When using integrated door position switch monitoring:

- Electric strikes are supplied with door magnet for cylindrical locksets only.
- Lockwood Mortice Locks and face plates are sold separately.
- All strikes are factory set to fail safe (PTL) configuration. Lock mode is easily set, post purchase, to fail secure (PTO) configuration, if required

Ordering Information

Product Description	Part Number
ES2100 Multifunction Strike 10-30Vdc Standard Lip with Extension Lip Holes	112100-000
ES2100 Multifunction strike 10-30Vdc No Lip	112100-010
ES2100 Multifunction strike 10-30Vdc 8mm Lip	112100-020

Accessories

Product Description	Part Number
Lockwood 3572 Series Primary lock with magnet face plate	3572MAGSC
Magnet face plate – suits Lockwood 3570 series mortice lock	SP3570-2100SSS
Mounting Kit	220200-519
13mm Rebate Plate	210100-541
25mm Extension Lip (40.5mm total)	220200-505
50mm Extension Lip (65.5mm total)	220200-506
75mm Extension Lip (90.5mm total)	220200-507

ES2600 Series Monitored Electric Strike

General Description

The ES2600 Series surface mounted electric strikes are high security products manufactured from solid stainless steel and designed to be used with existing and new panic bars fitted to emergency doors.

When used in conjunction with a standard access control system, these strikes convert “Exit only” doors with “Pullman type” latches into a full access controlled door, thereby allowing authorised access from the secure side.

The ES2600 series are fully monitored with both solenoid and latch/door monitoring functions & can be changed from fail safe to fail secure on site.

Key Features

- Fail safe/fail secure changeable on site
- High security
- Available in 12 or 24Vdc
- 650kg holding force
- 1 million cycles endurance rating
- Body depth only 27mm
- Cast stainless steel body
- Low current consumption – max 175Ma @ 12Vdc
- Continuously rated solenoid
- Installation template
- Australian designed
- **TRICARE**® 5 Year Warranty

Applications

- For use with panic bars
- Surface mount
- Egress doors
- Fire rated door sets
- Open out door sets
- Suitable for use with all access control systems



Standards and Compliance

-  Approved to UL1034 (highest level)
-  CE Approved
-  C-Tick Certified

ES2600 Series Monitored Electric Strike

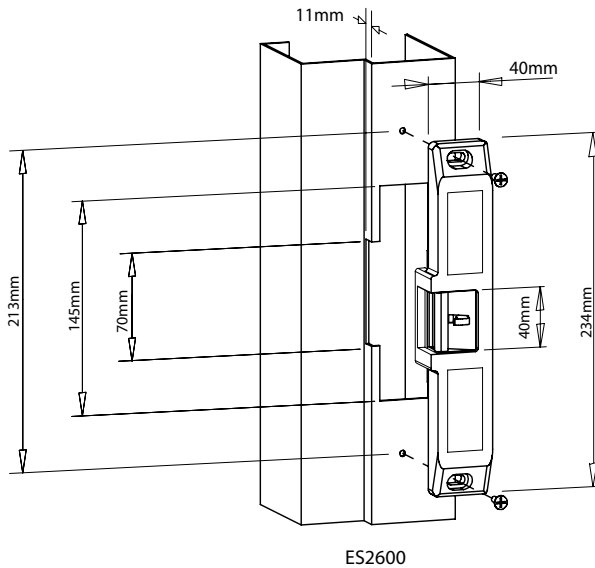

ES2600 Technical Information

Voltage	12 or 24Vdc
Current	175mA @ 12Vdc – 88mA @ 24Vdc
Solenoids	Solenoids rated for continuous use
Monitoring	Solenoid Monitor – 1 amp NO/NC microswitch Door / Latch Monitor – 1 amp NO/NC microswitch
Holding Force	650kg Static Strength Rating
Endurance	Cycle tested to 1,000,000 operations
Additional	Anti friction roller (patented) Suits panic bars with 15 to 20mm Pullman latch projection
Environment	Operational temperature range - 20C to +60C
Body	Solid Stainless Steel Construction
Keeper	Stainless Steel

Specification Statement

The strike should be constructed of solid stainless steel, have a minimum holding force of 650kg and have an endurance rating of 1 million cycles. Maximum penetration into the door frame should not exceed 12mm. The one strike must be changeable from fail safe to fail secure on site where required. The strike should not consume current greater than 175mA at 12Vdc and have a solenoid rated for continuous use. Certifications must include CE and C-Tick.

Ordering Information

Product Description	Part Number
12V Fail Safe with Roller Keeper for Panic Bar	112601-000

ES300 Series Electric Strike

General Description

The ES300 series electric strikes are designed for high security applications and manufactured from solid stainless steel.

These strikes are extremely flexible and can be changed from fail safe to fail secure and mounted on the left or right hand side of the door, thus reducing the amount of variants needed to cover each application.

Key Features

- Fail safe/fail secure changeable on site
- Available in 12 or 24Vdc
- 850kg holding force
- 1 million cycles endurance rating
- Stainless Steel locking pins
- Continuously rated solenoid
- Optional mounting kit
- **TRICARE**® 5 Year Warranty

Applications

- Timber or metal doors
- Open in/open out doors
- Suitable for use with all access control systems



Standards and Compliance

 Approved to UL1034 (highest level)

 CE Approved

 C-Tick Certified

ES300 Series Electric Strike

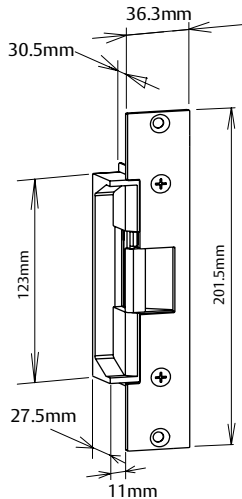

ES300 Wide Extension Lip

ES2600 Technical Information

Voltage	12 or 24Vdc
Current	175mA @ 12Vdc – 88mA @ 24Vdc
Solenoids	Solenoids rated for continuous use
Monitoring	None
Holding Force	850kg Static Strength Rating
Endurance	Cycle tested to 1,000,000 operations
Environment	Operational temperature range -20°C to +60°C
Body	Solid Stainless Steel Construction
Keeper	Stainless Steel
Latch	Suit 18mm latch bolt with 3 mm door gap

Specification Statement

The strike should be constructed of stainless steel, have a minimum holding force of 850kg and have an endurance rating of 1 million cycles. The one strike must be changeable from fail safe to fail secure on site where required. The strike should not consume current greater than 175mA @ 12Vdc and have a solenoid rated for continuous use. Certifications must include CE and C-Tick.

Ordering Information

Product Description
12V Fail Safe Large Stainless Steel Faceplate - Wide Ext Lip (SEC)
12V Fail Secure Large Stainless Steel Faceplate - Wide Ext Lip (SEC)
24V Fail Safe Large Stainless Steel Faceplate - Wide Ext Lip (SEC)
24V Fail Secure Large Stainless Steel Faceplate - Wide Ext (SEC)

Part Number
110321-030
110322-030
110323-030
110324-030

Accessories

Product Description	Part Number
Mounting Kit	220200-519

ES3000 Monitored Series Electric Strike

General Description

The ES3000 series electric strikes are designed for high security applications and manufactured from solid stainless steel.

These long ANSI strikes offer a strong dependable and long-lasting electric strike solution and are suitable for use with any access control system.

These strikes are extremely flexible and can be changed from fail safe to fail secure and mounted on the left or right hand side of the door, thus reducing the amount of stock needed to cover each application.

Key Features

- Fail safe/fail secure changeable on site
- Available in 12 or 24Vdc
- 850kg holding force
- Suitable for 18mm latches with 3mm door gap
- 1 million cycles endurance rating
- Stainless Steel locking pins
- Continuously rated solenoid
- Optional mounting kit
- Australian designed
- **TRICARE**® 5 Year Warranty

Applications

- Timber or metal doors
- Open in/open out doors
- Suitable for use with all access control systems



Standards and Compliance

 Approved to UL1034 (highest level)

 CE Approved

 C-Tick Certified

ES3000 Monitored Series Electric Strike

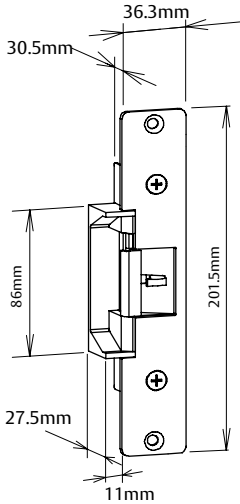

ES3000 ANSI Extension Lip

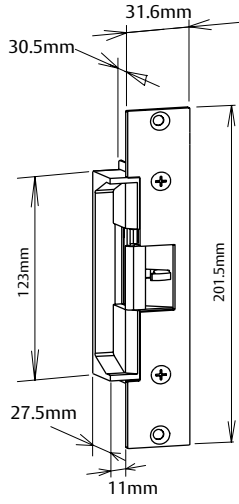

ES3000 Harcor Face Plate Wide Extension Lip

ES3000 Technical Information

Voltage	12 or 24Vdc
Current	175mA @ 12Vdc – 88mA @ 24Vdc
Solenoid	Solenoids rated for continuous use
Monitoring	Solenoid Monitor - 1 amp NO/NC microswitch Door / Latch - 1 amp NO/NC microswitch
Holding Force	850kg static strength rating
Endurance	Cycle tested to 1,000,000 operations
Environment	Operational temperature range -20°C to +60°C
Body	Solid stainless steel construction
Keeper	Stainless Steel

Specification Statement

The strike should be constructed of solid stainless steel, have a minimum holding force of 850kg and have an endurance rating of 1 million cycles. Monitoring must include independent door / latch & solenoid monitoring. The one strike must be changeable from fail safe to fail secure on site where required. The strike should not consume current greater than 175mA @ 12Vdc and have a solenoid rated for continuous use. Certifications must include CE and C-Tick.

Ordering Information

Product Description	Part Number
ES3000 Series - ANSI Extension LIP	
12V Fail Safe Large Stainless Steel Faceplate	113101-000
ES3000 Series - Wide Extension LIP	
12V Fail Safe Large Stainless Steel Faceplate (SEC)	113201-030
24V Fail Safe Large Stainless Steel Faceplate (SEC)	113203-030

ES9000 Series Pre-Load Strike

General Description

The ES9000 has been designed to suit the harshest commercial environments, and has the unique feature of the ability to operate with up to 25kg of pre-load pressure on the keeper. Pre-load is a common condition that is caused by pulling on a door before it unlocks, the weight of warped or drooping doors, seals on fire doors, or by differential air pressure created when heating and cooling systems are in use.

Standard features include multi voltage 10 - 30Vdc and field changeable settings from fail safe to fail secure.

Built to last, this is a premium locking solution that has been tested in excess of 2 million cycles and boasts unique features like no other available on the market today.

Key Features

- Operates under pre load up to 25kg
- Easy field selectable fail safe/fail secure
- Multi voltage 10-30Vdc
- 1300kg holding force
- 2.5 million cycles endurance rating
- Latch keeper is significantly quieter in operation
- Weather resistant
- Mounting tabs as standard
- Non handed
- Australian designed and made
- **TRICARE**® 5 Year Warranty

Applications

- High traffic areas
- Doors subjected to side load (pre load)
- Fire rated door sets
- Open in/open out doors
- Suitable for use with all access control systems



Standards and Compliance

S8 S8 (Security) Australian Lock Standard (AS4145.2.2008)

D8 D8 (Durability) Australian Lock Standard (AS4145.2.2008)



For Australian fire door applications, this Electric lock has been successfully fire rated for up to 4 hours on fire door assemblies in accordance with AS1905.1.2015 (Part 1: Fire resistant door sets). With a fire resistance level of 4 hours in accordance with AS1530.4-2014. Contact the supplier for further details, such as door type and door thickness etc that may affect the fire door suitability and rating.



CE & UKCA approved (EMC, RoHS and REACH)



RCM compliant

SCEC Endorsed for SL3 Medium Threat Level Areas

ES9000 Series Pre-Load Strike

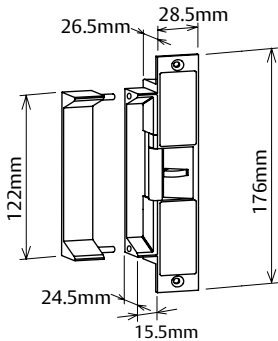

ES9000 with 25mm Extension Lip

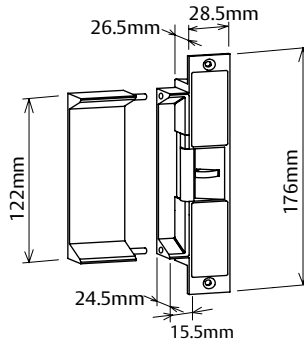

ES9000 with 50mm Extension Lip

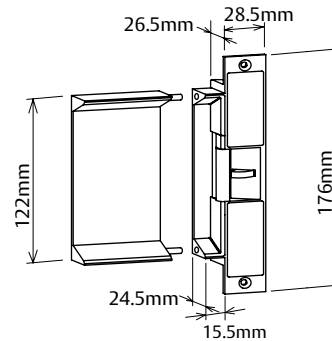

ES9000 with 75mm Extension Lip

ES9000 Pre-Load Strike Technical Information

Voltage	10 – 30Vdc
Current	250mA @12Vdc – 130mA @24Vdc
Solenoids	Solenoid rated for continuous use
Electrical protection	Polarity and back EMF protected
Monitoring	Solenoid Monitor – 1 amp NO/NC microswitch Door / Latch Monitor – 1 amp NO/NC microswitch
Holding force	1300kg static strength rating
Endurance	1,200,000 cycles endurance rating @ 25kg pre-load 2,500,000 cycles general durability without pre-load conditions
Latching	Suitable for 15mm latch with 3mm door gap
Environment	Operational temperature range - 20C to +60C
Body	Solid Stainless Steel Construction
Keeper	Stainless Steel

Ordering Information

Product Description	Part Number
ES9000 Pre - Load Multi Function Strike with Standard 15.5mm Lip	119001-000
ES9000 Pre - Load Multi Function Strike - No Lip	119001-010
ES9000 Pre - Load Multi Function Strike - 8mm Lip	119001-020
ES9000 Pre - Load Multi Function Strike - with Extension Lip Holes	119001-060
25mm Lip Extension (40.5mm Total) to suit 119001-060	220200-505
50mm Lip Extension (65.5mm Total) to suit 119001-060	220200-506
75mm Lip Extension (90.5mm Total) to suit 119001-060	220200-507

Note: All ES9000 series electric strikes are supplied in Fail Safe configuration.

Specification Statement

The electric strike should be fully monitored and have independent door / latch and solenoid monitor switches. Holding force for the strike should be not less than 1300kg.

Where Power to Lock and Power to Open functions may be required in the same building, a single electric strike should be interchangeable from either fail safe or fail secure from the rear of the strike.

The electric strike should not consume current greater than 250mA @ 12Vdc and have a solenoid rated for continuous use. A fire rating not less than 4 hours is required where applicable. The strike must be capable of operating with up to 25kg of pre-load pressure applied to the keeper, be tested to 2.5 million operations and carry a minimum warranty of 5 years.

ES9100 Series Pre-Load Strike with Door Position Monitoring

General Description

Following on from the extremely popular and industry leading Trimec ES9000 Pre-Load Electric Strike, the Trimec ES9100 Electric Strike provides all the key features and specifications of the ES9000 but with the added inclusion of Door Position Monitoring (DPS) via an integrated Reed Switch. The ES9100 body is also pre-drilled for the inclusion of 25mm, 50mm or 75mm Extension Lips, if required.

The Trimec Series ES9100 has been designed to suit the harshest commercial environments, and has the unique feature of the ability to operate with up to 25kg of pre-load pressure on the keeper. Pre-load is a common condition that is caused by pulling on a door before it unlocks, the weight of warped or drooping doors, seals on fire doors or by differential air pressure created when heating and cooling systems are in use. Standard features include multi voltage 10 - 30VDC and field changeable settings from fail safe to fail secure. Built to last, this is a premium locking solution that has been tested in excess of 2 million cycles and boasts unique features like no other available on the market today.

Key Features

- Operates under pre load up to 25kg
- Door Position Monitoring Output
- Lock Status and Latch Position Monitoring Output
- Easy field selectable fail safe/fail secure
- Multi voltage 10-30VDC
- 1300kg holding force
- 2.5 million cycles endurance rating
- Latch keeper is significantly quieter in operation
- Weather resistant (IP54)
- Pre-Drilled for Extension Lips
- Mounting tabs included
- Non handed
- **TRIGRE®** 5 Year Warranty (Padde Series)
- Built in Protection Diode

Applications

- High traffic areas
- Doors subjected to side load (pre load)
- Fire rated door sets
- Inward and Outward opening doors
- Suitable for use with all access control systems



Standards and Compliance

S8 S8 (Security) Australian Lock Standard (AS4145.2.2008)

D8 D8 (Durability) Australian Lock Standard (AS4145.2.2008)



For Australian fire door applications, this Electric lock has been successfully fire rated for up to 4 hours on fire door assemblies in accordance with AS1905.1.2015 (Part 1: Fire resistant door sets). With a fire resistance level of 4 hours in accordance with AS1530.4-2014. Contact the supplier for further details, such as door type and door thickness etc that may affect the fire door suitability and rating.

CE UK CA CE & UKCA approved (EMC, RoHS and REACH)

 RCM compliant

ES9100 Series Pre-Load Strike with Door Position Monitoring

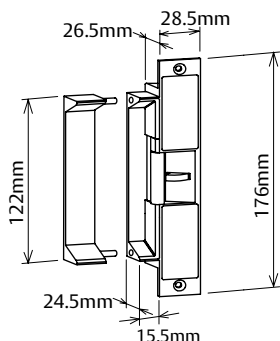

ES9100 with 25mm Extension Lip

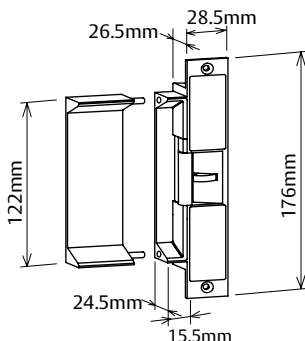

ES9100 with 50mm Extension Lip

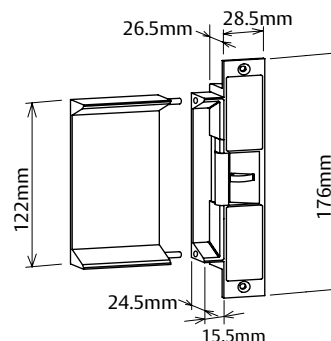

ES9100 with 75mm Extension Lip

ES9100 Pre-Load Strike Technical Information

Voltage:	10 to 30VDC
Current:	250mA @ 12VDC, 130mA @ 24VDC
Monitoring:	Solenoid (1 Amp NO/NC), Door/Latch (1 Amp NO/NC) Door Position (1 Amp NC)
Holding Force:	1300kg Static Strength Rating
Endurance:	1,200,000 cycles @ 25kg Pre-Load, 2,500,000 cycles without Pre-Load
Latching:	Suitable for use with 15mm Latch and 3mm Door Gap
Environment:	Operating Temperature range -20C to +60C, IP54 Rating
Body:	Solid Stainless Steel Construction
Keeper:	Stainless Steel

Specification Statement

The electric strike should be fully monitored, including Door Position, independent door/latch and solenoid monitoring outputs. Holding force for the strike should be not less than 1300kg. Where Power to Lock and Power to Open functions may be required in the same building, a single electric strike should be interchangeable from either fail safe or fail secure from the rear of the strike. The electric strike should not consume current greater than 250mA @ 12Vdc and have a solenoid rated for continuous use. A fire rating not less than 4 hours is required where applicable. The strike must be capable of operating with up to 25kg of pre-load pressure applied to the keeper, be tested to 2.5 million operations and carry a minimum warranty of 5 years.

Ordering Information

Product Description	Part Number
Trimec ES9100 Electric Strike, 10-30VDC, Preload, Door Position Monitoring, Ext Lip Holes	119100-000
13mm Rebate Plate	210100-541
25mm Extension Lip (40.5mm total)	220200-505
50mm Extension Lip (65.5mm total)	220200-506
75mm Extension Lip (90.5mm total)	220200-507

Note: All ES9100 series electric strikes are supplied in Fail Safe (PTL) configuration.



Tested to 3 million cycles... and counting

The ES9000 is now approved by the Security Construction and Equipment Committee (SCEC) for Access Control in Secure Areas (Security Level 3).

- Operates under Pre-load up to 25 kg
- Easy field selectable fail safe / fail secure
- Multi voltage 10- 30 Vdc
- Designed and manufactured in Australia





ASSA ABLOY

Demand The Original

SINCE ITS LAUNCH MANY HAVE TRIED TO COPY TRIMEC
AND FAILED. TRIMEC, OFTEN IMITATED, NEVER DUPLICATED.



trimec.com.au

ASSA ABLOY

An ASSA ABLOY Group brand

MC00139 ASSA ABLOY Australia Pty Limited ABN 90 086 451 907 © 2011



ASSA ABLOY is the global leader in door opening solutions, dedicated to satisfying end-user needs for security, safety and convenience.

ASSA ABLOY is represented in all major regions, in both mature and emerging markets, with leading positions in Australia, Europe and North America.

As the world's leading lock group, ASSA ABLOY offers a more complete product range of door opening solutions than any other company on the market.

ASSA ABLOY
Opening Solutions

Head Office

ASSA ABLOY Australia Pty Limited
235 Huntingdale Road
Oakleigh Victoria 3166
Australia

+61 (3) 8574 3888
exportem@assaabloyasiapacific.com
assaabloyopeningsolutions.com.au

