

Recording  
&  
Playback

# SENSOR SPEAKER

PV-12 (Power:12VDC with contact output)



*Sensor Speaker announces recorded message when sensor detects movement.*

**General Description**

Sensor Speaker is the product which combines a passive infrared sensor and a speaker to detect the infrared (=body temperature) emitted from a human body or vehicles and to trigger recorded message. Sensor Speaker is designed for wide applications such as announcement speaker in various facilities or as alarm/warning speaker at dangerous areas like construction sites.

**Horn speaker with PIR sensor**

It announces a message only when the built-in sensor detects people or cars. The horn speaker with max. 100dB/(1m ahead) will be suitable for professional use.

**Easy recording and playback**

Max. recording time:12 sec. Simple recording by using the microphone. Possible to record various messages any time, so applications are various.

**Output contact convenient to trigger other systems**

Dry contact relay equipped. Easy to connect to lights, chimes buzzer, and camera system, etc.

**Others**

- Sound volume adjustment.
- Record message in EEPROM.
- Rainproof.

**For various applications:**



Alarm/warning speaker at constructions site

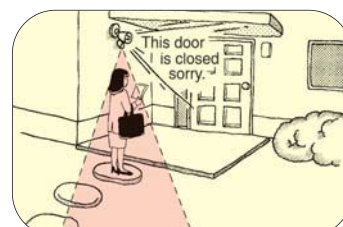

Announcement speaker at houses

## COVERAGE (m/feet)

TOP VIEW

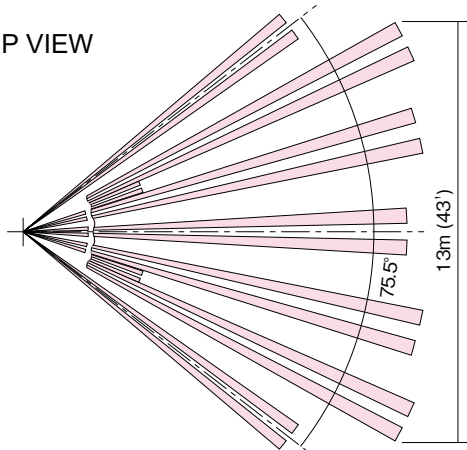

SIDE VIEW

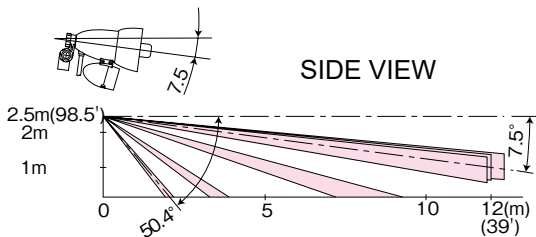

## EXTERNAL DIMENSIONS

[Unit : inch(mm)]

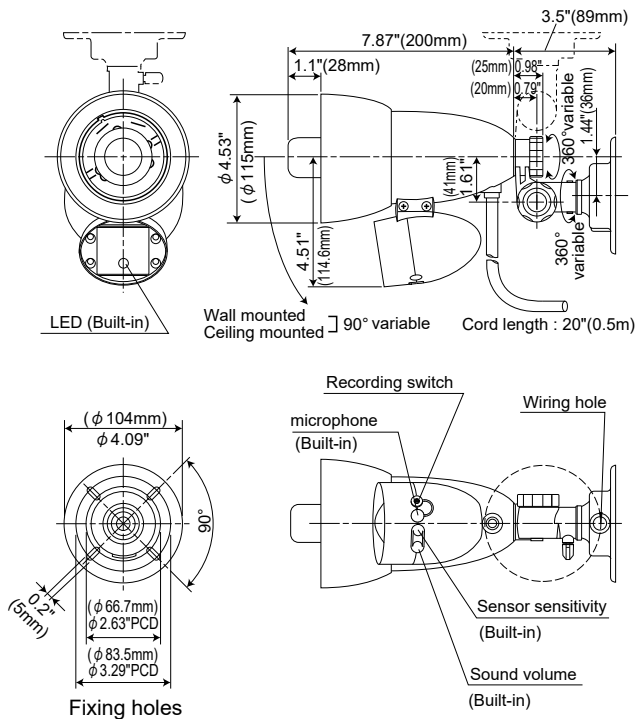

## WIRING

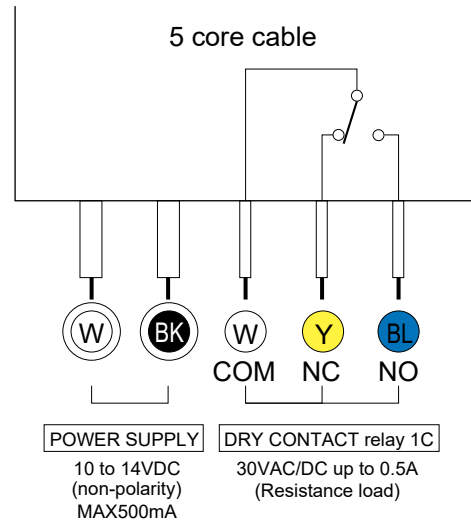

## SPECIFICATIONS

Description	Sensor Speaker
Model	PV-12
Detection system	Passive infrared
Detection area	Wide angle 40'(12m)Max.
Sensitive zone	24 zones (12 pairs)
Sensitivity adjustment	Variable 20%(L) to 180%(H) (medium : 100%)
Power supply	10 to 14VDC (non-polarity)
Current consumption	20mA or less(Stand by) 500mA or less (Max.)
Alarm output	Dry contact relay : form C AC/DC 30V 0.5A (Resistive load) Contact operation : synchronized with recoding time.(Min 2 secs.)
Warm up time	60 secs. (no detection, recording O.K.)
Sound synthesis method	PCM method
Record method	Built-in condenser microphone
Record / Playback time	Max 12 secs.
Sound output	Operation : One-shot playback (12 sec.) by detection signal (No retrigger during playback)  Sound volume : Max.100dB/2W(1m ahead) at right recording level Adjustable from 0 to Max by volume switch
Indication LED	Warm up : Blinking Recording level is indicated : "Blinking" : good "ON" : too low "OFF" : too loud Playback : ON(during playback)
Ambient temperature	-20°C to + 50°C without condensation and freeze
Mounting position	Indoor / outdoor (rainproof)
Weight	Approx.1000g
Appearance	Body: Resin(Black)

\*The specifications are subject to change without notice.

**Please note:** This sensor is designed to detect intrusion to give an audio message ; it is not a burglary or a crime preventing device.  
TAKEX is not responsible for damage, injury or losses caused by accident, theft, Acts of God (including inductive surge by lightning), abuse, misuse, abnormal usage, faulty installation or improper maintenance.

# TAKEX

### In Japan

**Takenaka Engineering Co., Ltd.**  
83-1, Gojo-Dori, Sotokan Nishi-iru, Higashino,  
Yamashina-ku, Kyoto 607-8156, Japan  
Tel : 81-75-501-6651  
Fax : 81-75-593-3816  
<https://www.takex-eng.co.jp/>

### In the U.S.

**Takex America Inc.**  
151, San Zeno WAY  
Sunnyvale, CA 94086, USA  
Tel : 408-747-0100  
Fax : 408-734-1100  
<https://www.takex.com>

### In Australia

**Takex America Inc.**  
4/15 Howleys Road, Notting Hill,  
VIC, 3168  
Tel : +61 (03) 9544-2477  
Fax : +61 (03) 9543-2342  
<https://www.takex.com>

### In the U.K.

**Takex Europe Ltd.**  
Aviary Court, Wade Road,  
Basingstoke, Hampshire. RG24 8PE, U.K.  
Tel : (+44) 01256-475555  
Fax : (+44) 01256-466268  
<https://www.takex.com>